



855-895-1907

WWW.NATIONWIDETANKS.COM

CUSTOMER: SON 234
 TANK TYPE: FTFNTD0816051 8'X 5K
 WEIGHT: 5,600
 LENGTH: 17'6"

BILL OF MATERIALS / SCHEDULE

A	(1) 4" INTERSTITIAL FITTING
B1	(1) 4" FULL COUPLING
M1	(1) 24" MANWAY

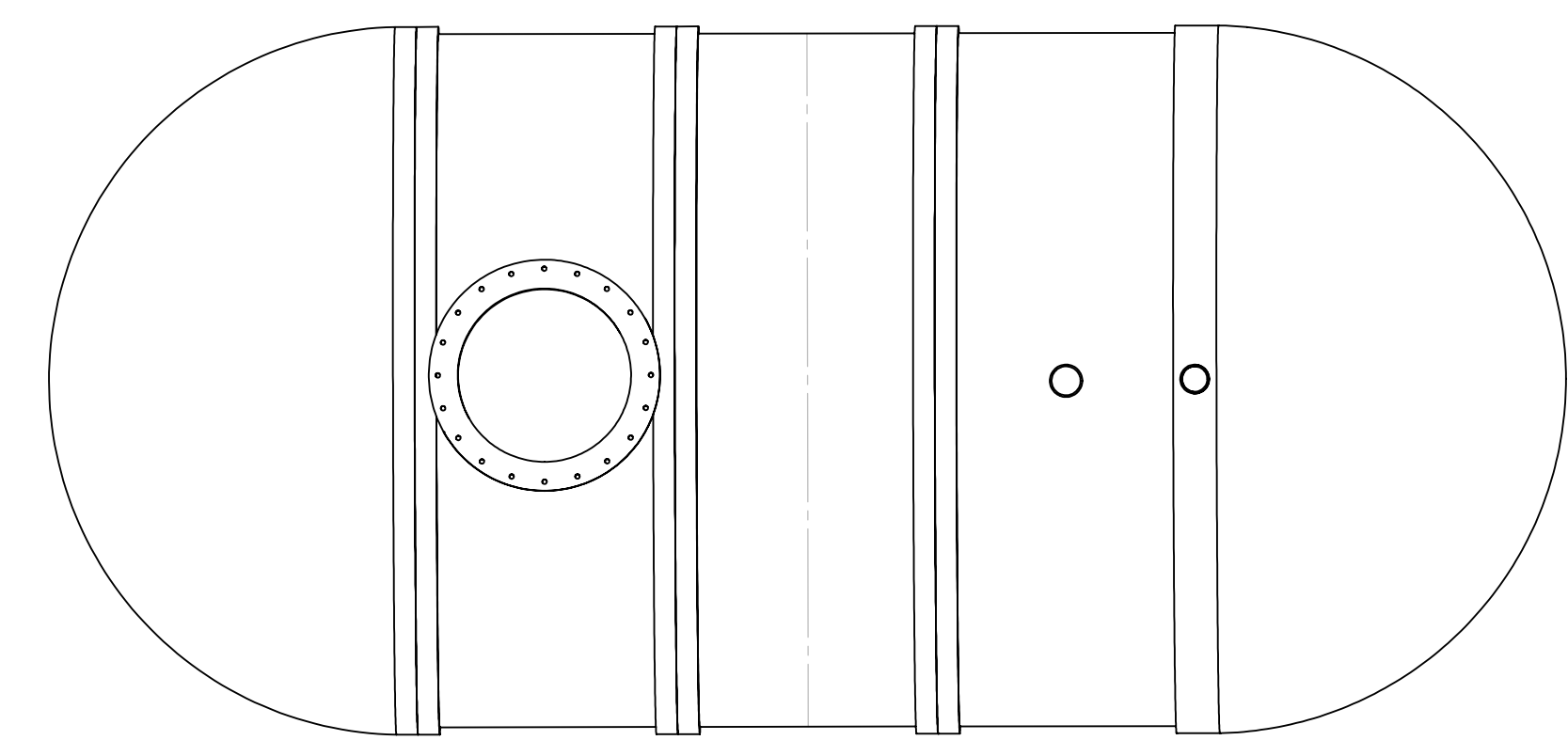

FTFNTD0816051 8'X 5K

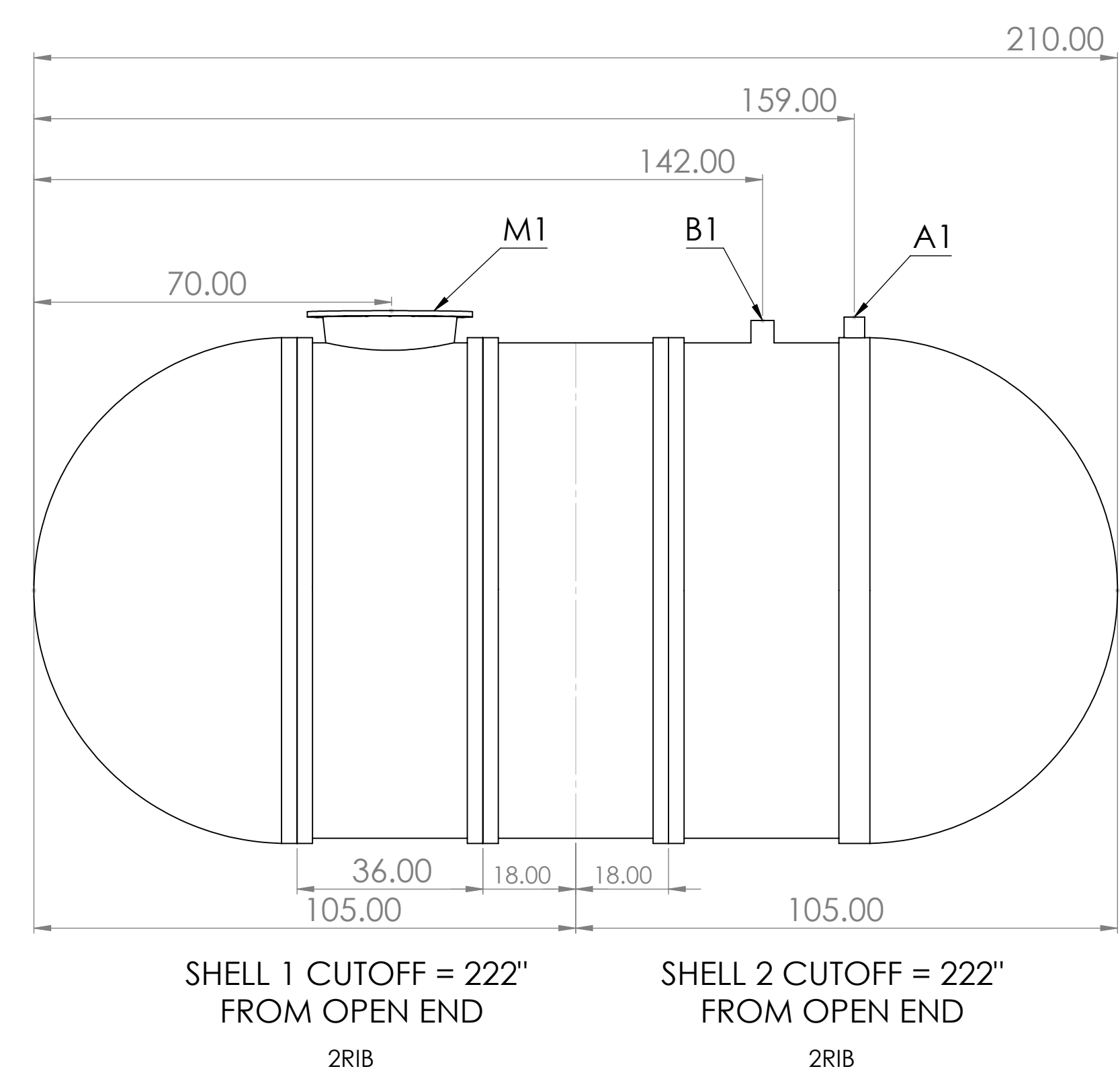

SAVED AS: FTFNTD0816051 8X5 STOCK

TANK FABRICATION NOTES:

DRAWN BY: JR DATE: 11/3/2023

CHECKED BY: DATE:

APPRD BY: DATE:

RESIN	CATALYST	MATRIX
F798	MEKP	C-VEIL

PROPRIETARY INFORMATION : The information contained herein is property to NATIONWIDE TANKS INC, and shall not be reproduced or disclosed in whole or in part or used for any design or manufacture except when user possesses direct written authorization from NATIONWIDE TANKS INC. NOTE : Fuel Tanks are designed, manufactured, inspected, and tested in accordance with UL/ULC 1316 Third Edition under project # 4790834407. Helical Armor Tank®, Dynamic Band Technology®, and OxyShield Resin System® are registered trademarks of NATIONWIDE TANK INC - Patent pending. GENERAL NOTES: ALL BOLT HOLES TO STRADDLE NORMAL TANK CENTERLINES UNLESS OTHERWISE SHOWN *NOZZLE PROJECTIONS ARE 6" FROM OUTSIDE OF THE TANK TO FACE OF FLANGE UNLESS OTHERWISE SHOWN *COUPLING TO BE 2" PROJECTION ON SIDE WALL OF TANK *12" X 12" STRIKER PLATE MUST BE INSTALLED AT BOTTOM OF TANK WALL UNDER EACH COUPLING (WITH THE EXCEPTION OF VENT ONLY COUPLINGS) *24" X 24" STRIKER PLATE INSTALLED AT BOTTOM OF TANK WALL UNDER ACCESS OPENING.