

NOTES: UNLESS OTHERWISE SPECIFIED

1. ALL BOLT HOLES TO STRADDLE NORMAL TANK CENTERLINES UNLESS OTHERWISE SHOWN
2. NOZZLE PROJECTIONS ARE 6" FROM OUTSIDE OF TANK TO FACE OF FLANGE UNLESS OTHERWISE SHOWN
3. COUPLING TO BE 2" PROJECTION ON SIDE WALL OF TANK
4. STRIKER PLATE (12" X 12") MUST BE INSTALLED AT BOTTOM OF TANK WALL UNDER EACH COUPLING (WITH THE EXCEPTION OF VENT ONLY COUPLINGS).
5. STRIKER PLATE (24" X 24") MUST BE INSTALLED AT BOTTOM OF TANK WALL UNDER MANWAY ACCESS OPENING.
6. TANK DESIGNED, FABRICATED, INSPECTED/TESTED IN ACCORDANCE WITH UL/ULC -1316 SPEC'S CURRENT EDITION.
7. TRAFFIC RATE TANK - LID MUST BE RECESSED IN CONCRETE SLAB
8. DEADMEN, STRAPS, TURNBUCKLES, AND INSTALLATION SHACKLES ARE NOT INCLUDED

SON # 235

8K CAPACITY

REVISIONS			
REV	DESCRIPTION	DATE	APPVD
01	INITIAL RELEASE	07/25/2023	

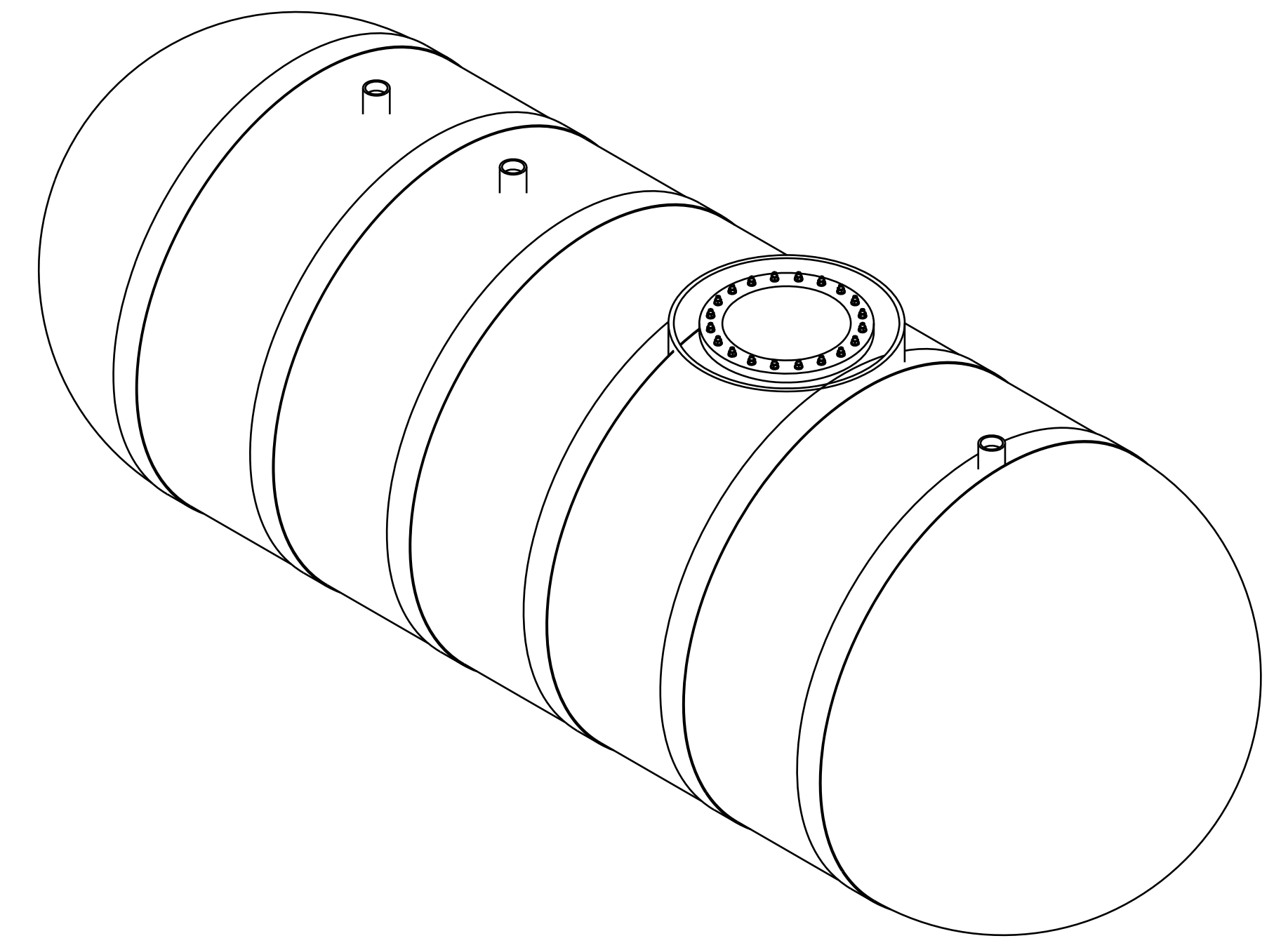

ISO VIEW

LABEL	SIZE	MATL.	DESCRIPTION	ADDITIONAL ACCESSORIES - NOTES	QTY
A1	4"	FRP	HALF COUPLING	PROBE RIB	1
B1	4"	FRP	HALF COUPLING	W/ 12" X 12" STRIKER PLATE	2
M1	24"	FRP	MANWAY	W/ 24" X 24" STRIKER PLATE	0
M2	-	C.S.	MANWAY COVER	SEE MANWAY COVER DWG	0
M3	42"	FRP	COLLAR	REFER TO BRAVO PRODUCTLINE	0
LL	-	GALV.	LIFTING LUGS	LIFTING LUG (REFER TO DWG: NTP-10D011)	6
DM	-	-	ANCHOR SYSTEM	4x 22' LONG SLOTTED CONCRETE ANCHOR W/GALV. ANCHOR POINTS	0
TDS	-	-	STRAP ASSEMBLY	D-RINGS GLASSED TO FRP STRAP; 1/2" THK TO BE USED IN ANCHORING TANK TO DEADMAN, USING SHACKLES, & TURN- BUCKLE PER STRAP	0
TB	-	-	TURNBUCKLES		0

COMPANY: _____

DATE: _____

NAME (PRINTED): _____

[] APPROVED: _____

[] REDRAW AND RESUBMIT: _____

SHIPPING INFO:

MAX LENGTH = 23' - 9"
 MAX HEIGHT = 9' - 6" (W/O SUMP RISER)
 MAX WIDTH = 8' - 8"
 TANK WEIGHT = 6,600 LBS

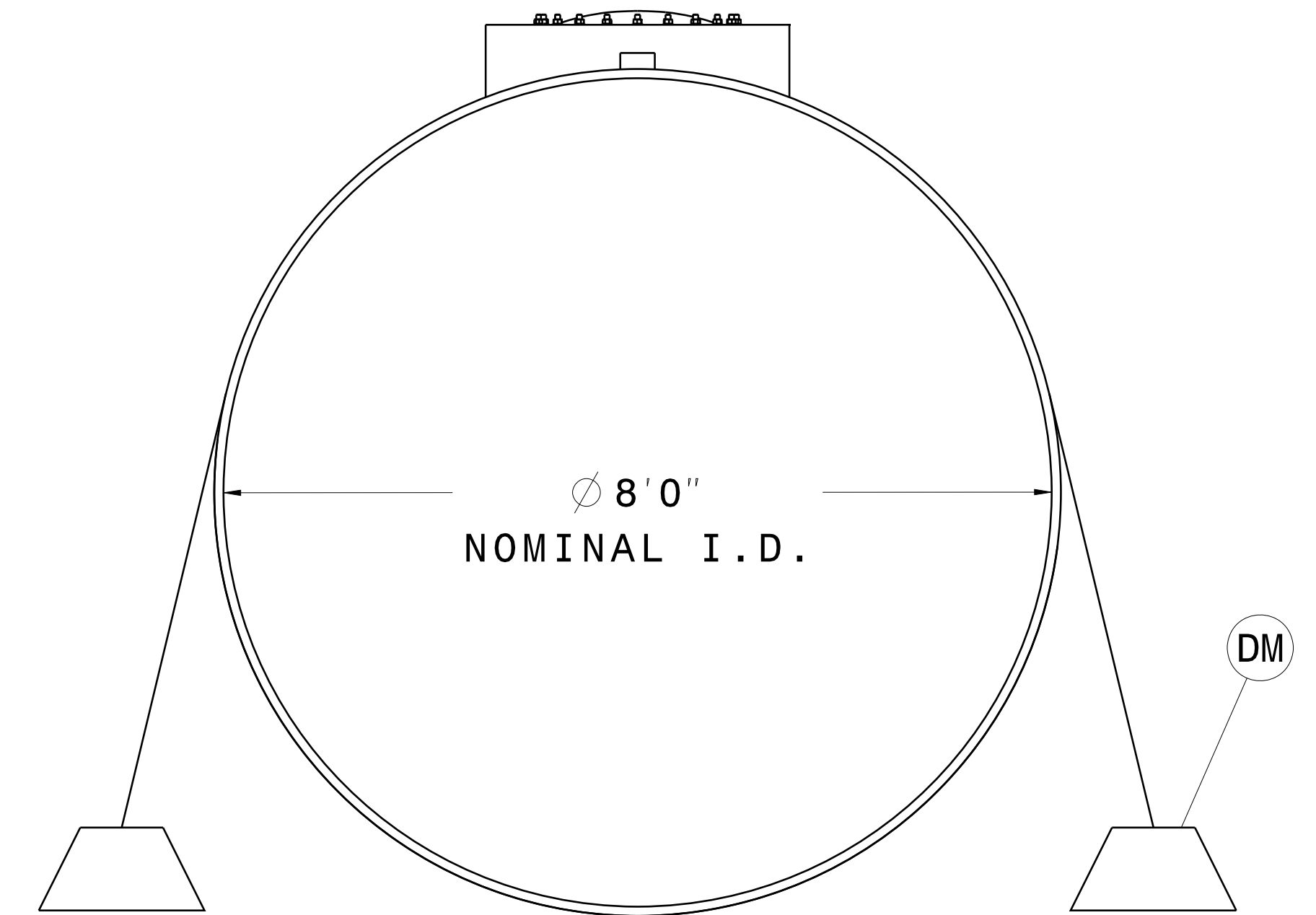

END VIEW

CONTROLLED COPY

ALL INFORMATION WITHIN THIS DRAWING IS CONSIDERED CONFIDENTIAL, PROPRIETARY INFORMATION

DIMENSIONS ARE IN INCHES UNLESS OTHERWISE SPECIFIED. BREAK EDGES/REMOVE BURRS.		MATERIAL:		DWG NAME:	
ANGLES - 1:2:0°	1:1:1°	FRP	FRP	8' x 8K FRP STOCK FUEL TANK	
SCALE:	SHEET:	SCALE:	SHEET:	SON #:	REV: 01
APPLICATION	USED ON	NONE	D		SHEET: 1 OF 2



SON # 235
 8K CAPACITY

TOP VIEW

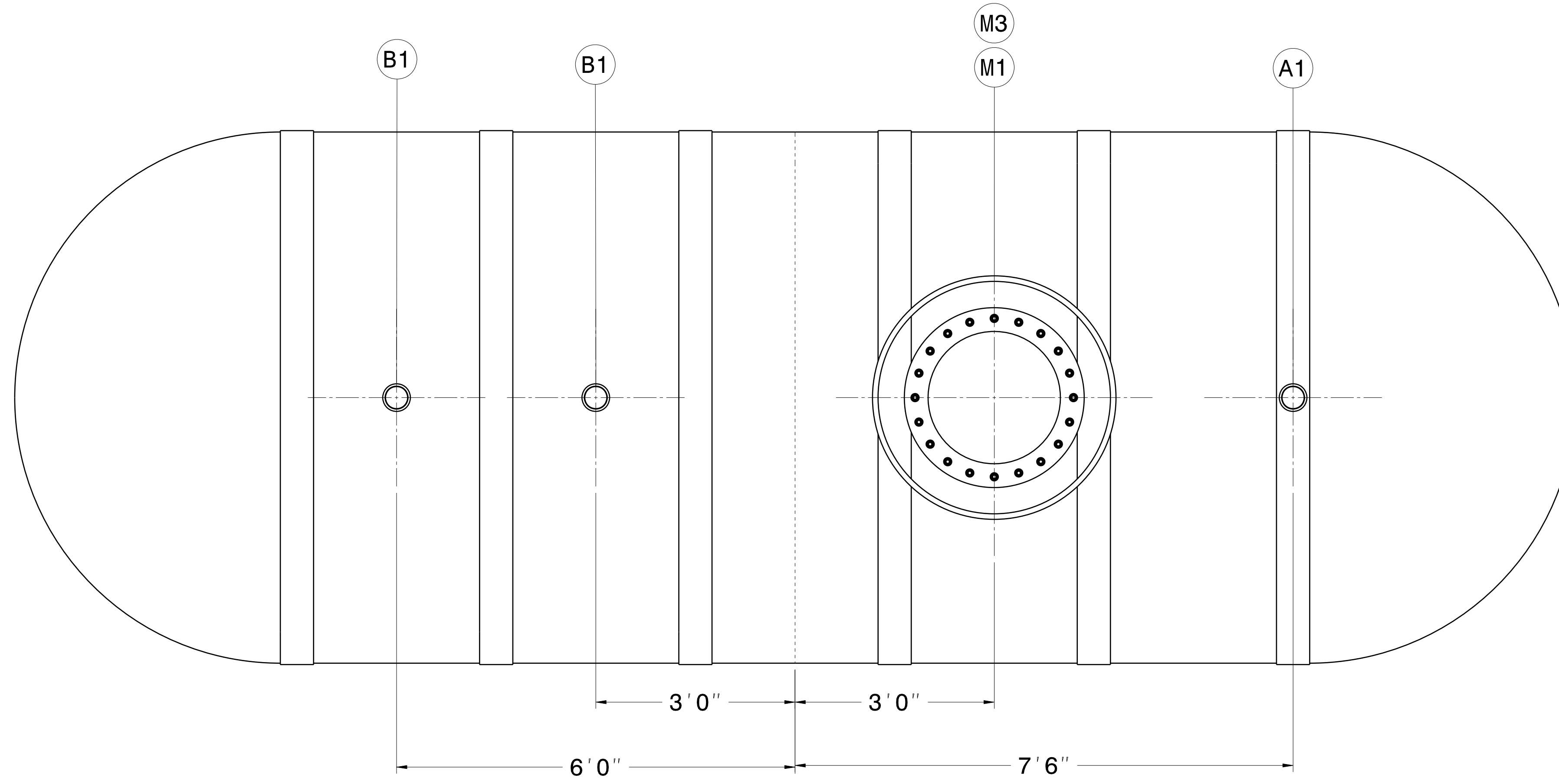

SIDE VIEW

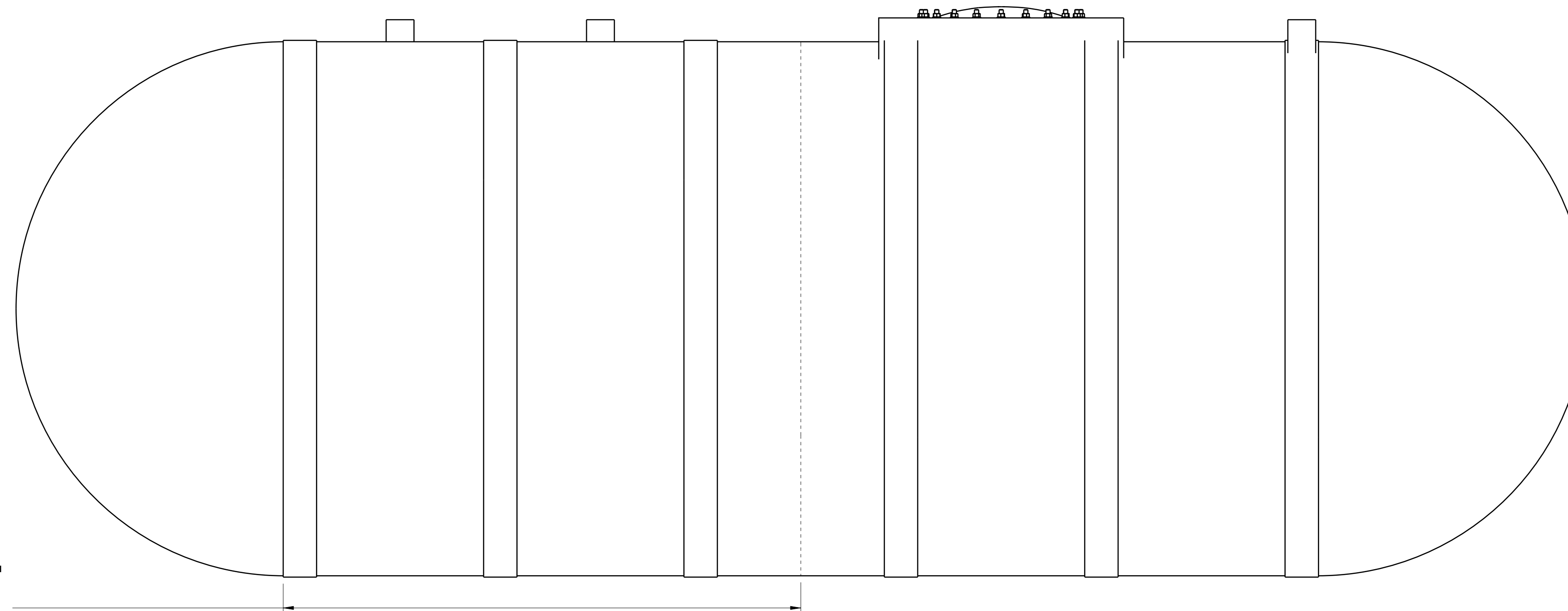

RECIPE LENGTH = 129"
 SHELL 1 & 2 = 7'9"
 CUT-LINE = 219"