

NOTES: UNLESS OTHERWISE SPECIFIED

1. ALL BOLT HOLES TO STRADDLE NORMAL TANK CENTERLINES UNLESS OTHERWISE SHOWN
2. NOZZLE PROJECTIONS ARE 6" FROM OUTSIDE OF TANK TO FACE OF FLANGE UNLESS OTHERWISE SHOWN
3. COUPLING TO BE 2" PROJECTION ON SIDE WALL OF TANK
4. STRIKER PLATE (12" X 12") MUST BE INSTALLED AT BOTTOM OF TANK WALL UNDER EACH COUPLING (WITH THE EXCEPTION OF VENT ONLY COUPLINGS).
5. STRIKER PLATE (24" X 24") MUST BE INSTALLED AT BOTTOM OF TANK WALL UNDER MANWAY ACCESS OPENING.
6. TANK DESIGNED, FABRICATED, INSPECTED/TESTED IN ACCORDANCE WITH UL/ULC -1316 SPEC'S CURRENT EDITION.
7. TRAFFIC RATE TANK - LID MUST BE RECESSED IN CONCRETE SLAB
8. DEADMEN, STRAPS, TURNBUCKLES, AND INSTALLATION SHACKLES ARE NOT INCLUDED

# SON # 252

## 12K CAPACITY

REVISIONS			
REV	DESCRIPTION	DATE	APPVD
02	UPDATED with Donna's Feedback 2Rib + 3 Rib	07/17/23	
01	Updated with 3" offset	05/16/23	
IR	INITIAL RELEASE	05/15/23	

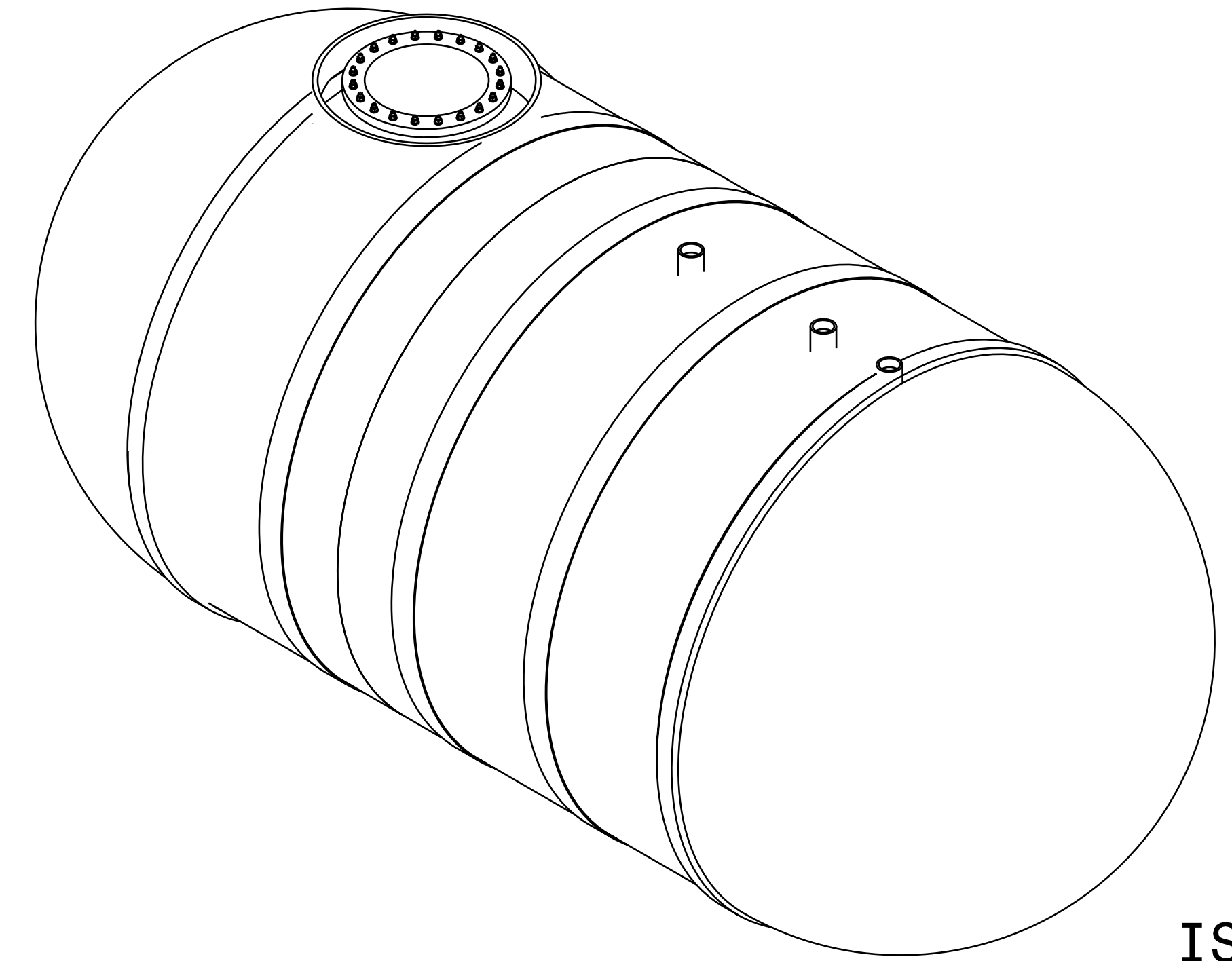

ISO VIEW

LABEL	SIZE	MATL.	DESCRIPTION	ADDITIONAL ACCESSORIES - NOTES	QTY
A1	4"	FRP	HALF COUPLING	PROBE RIB	1
B1	4"	FRP	HALF COUPLING	W/ 12" X 12" STRIKER PLATE	2
M1	24"	FRP	MANWAY	W/ 24" X 24" STRIKER PLATE	1
M2	-	C.S.	MANWAY COVER	SEE MANWAY COVER DWG	0
M3	42"	FRP	COLLAR	REFER TO BRAVO PRODUCTLINE	1
LL	-	GALV.	LIFTING LUGS		4
PL	-	GALV.	POSITION LUGS		2
DM	-	-	ANCHOR SYSTEM	22' LONG SLOTTED CONCRETE ANCHOR W/GALV. ANCHOR POINTS	0
TDS	-	-	STRAP ASSEMBLY	D-RINGS GLASSED TO FRP STRAP; 1/2" THK TO BE USED IN ANCHORING TANK TO DEADMAN, USING SHACKLES, & TURN- BUCKLE PER STRAP	0
TB	-	-	TURNBUCKLES		0

### SHIPPING INFO:

MAX LENGTH = 22' - 6"  
 MAX HEIGHT = 12' - 6" (W/O SUMP RISER)  
 MAX WIDTH = 11' - 0"  
 TANK WEIGHT = 8,000 LBS  
 DEADMEN WEIGHT = 5,500 LBS

COMPANY: \_\_\_\_\_

DATE: \_\_\_\_\_

NAME (PRINTED): \_\_\_\_\_

[ ] APPROVED: \_\_\_\_\_

[ ] REDRAW AND RESUBMIT: \_\_\_\_\_

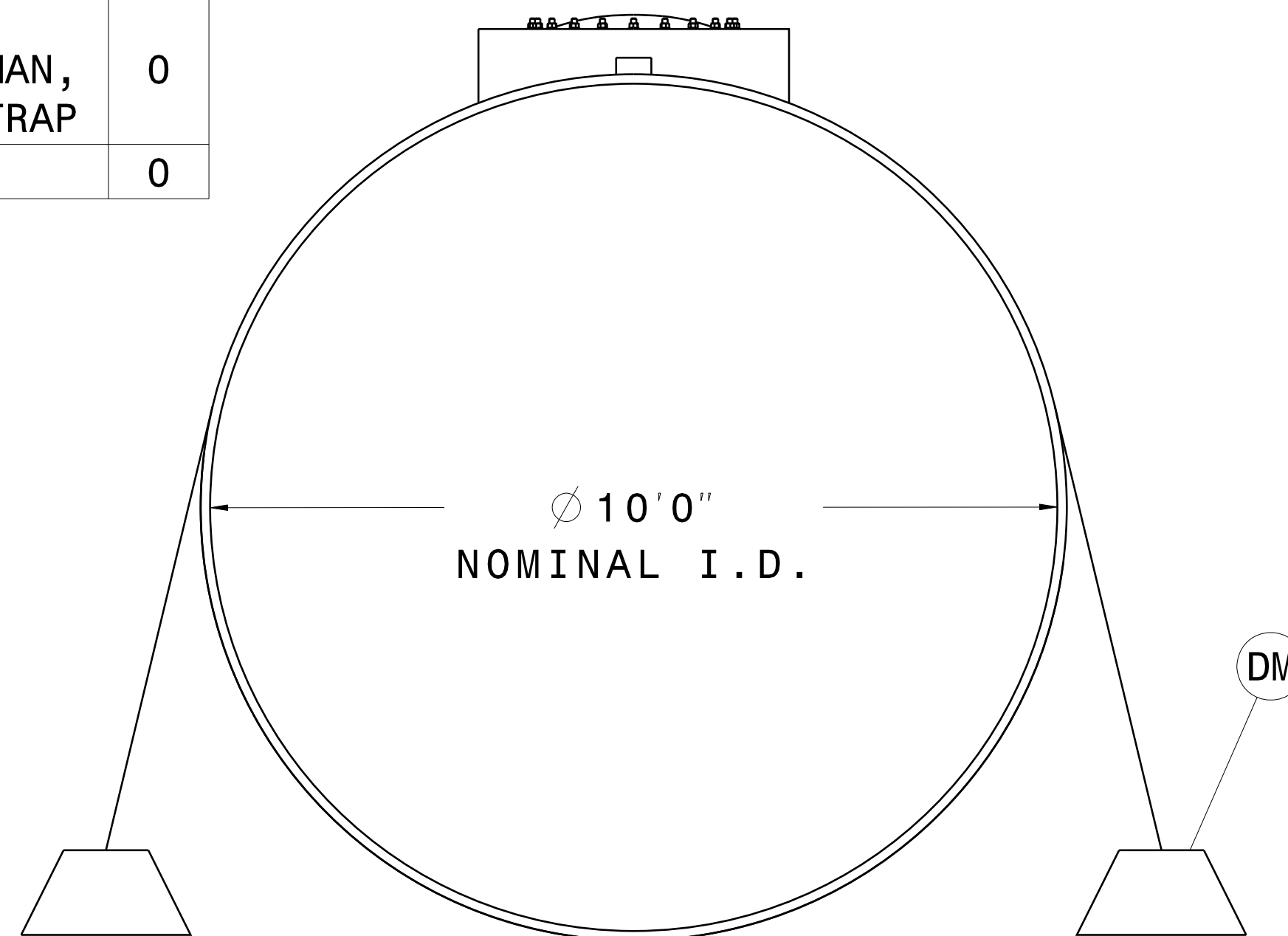

END VIEW

CONTROLLED COPY

ALL INFORMATION WITHIN THIS DRAWING IS CONSIDERED CONFIDENTIAL, PROPRIETARY INFORMATION

DIMENSIONS ARE IN INCHES UNLESS OTHERWISE SPECIFIED. BREAK EDGES/REMOVE BURRS.		MATERIAL:		DWG NAME:	
ANGLES - 1:2:0°	SCALE:	10'x12K STOCK FRP FUEL TANK	NATIONWIDE TANKS		
ARC - 1:2:0°	SCALE:	D	SHEET: 1 OF 2		
DO NOT SCALE DRAWING	SCALE:	D	REV: 01		
CAGE CODE:	SCALE:	D	SHEET: 1 OF 2		

SON # 252  
 12K CAPACITY

TOP VIEW

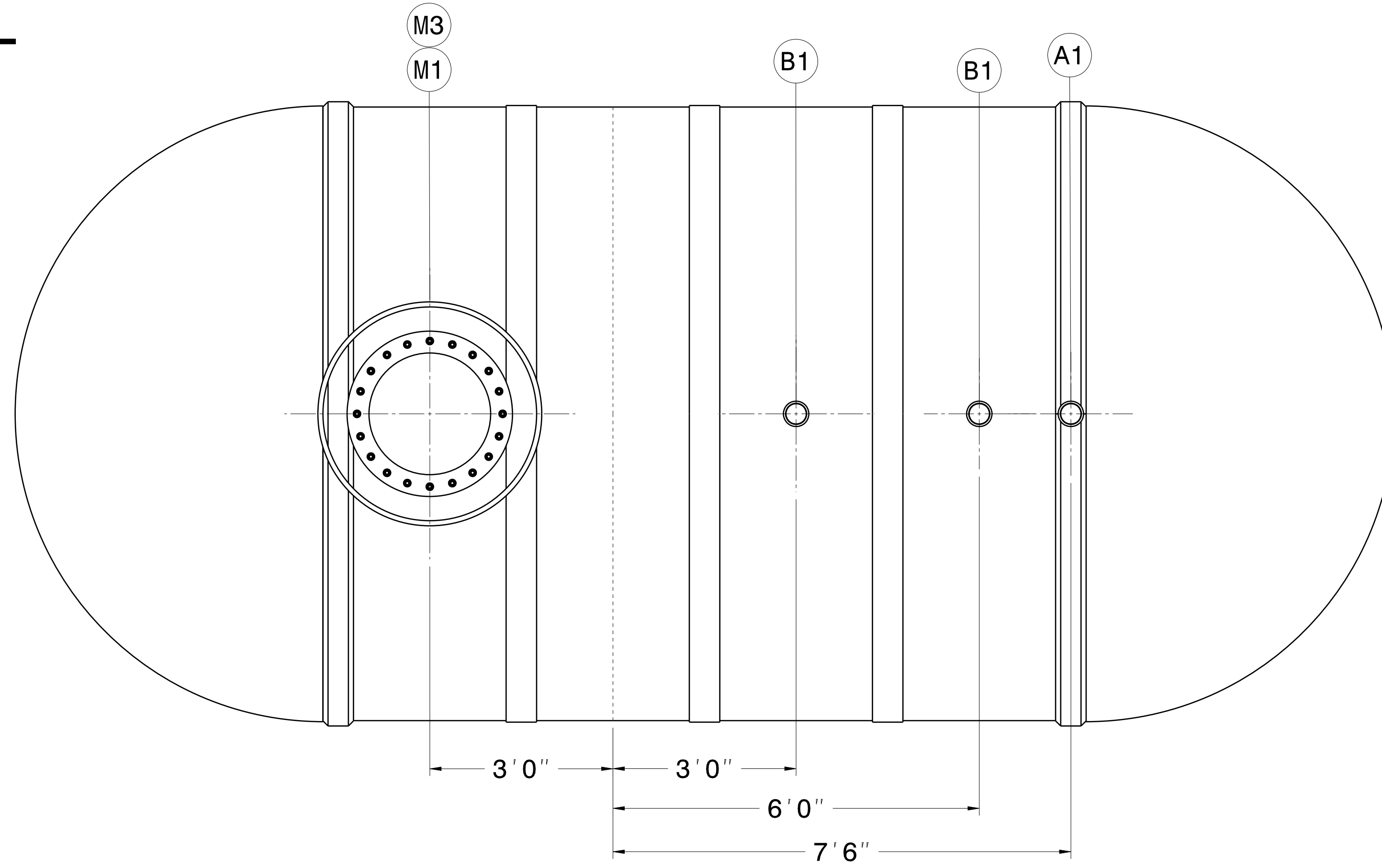

SIDE VIEW

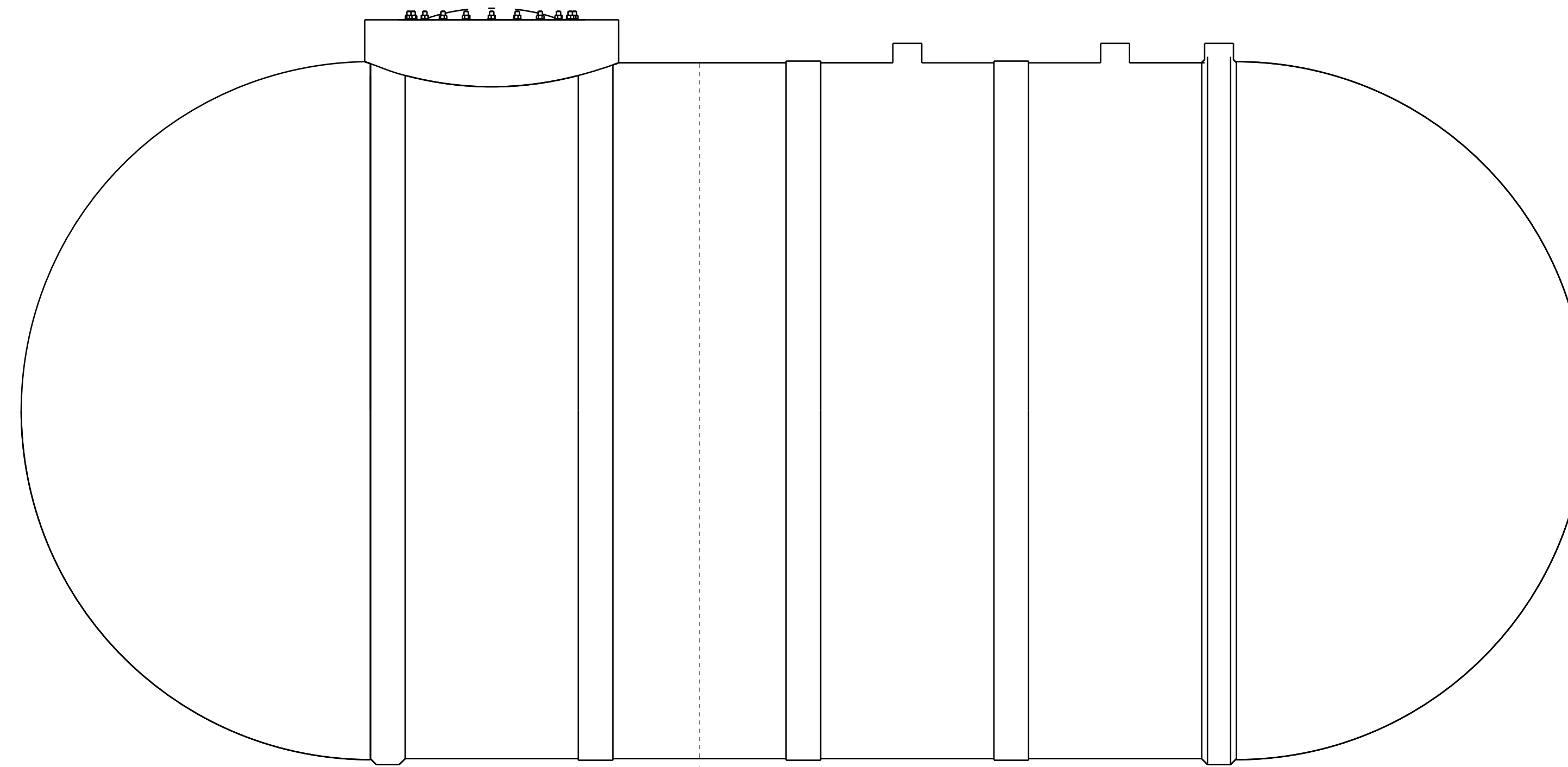

RECIPE LENGTH = 93"  
 SHELL 1 LENGTH = 4'9"  
 CUT-LINE = 255"

RECIPE LENGTH = 129"  
 SHELL 2 LENGTH = 7'9"  
 CUT LINE = 219"